

Incredible **100,000 hrs**

GENERAL DESCRIPTION

Neptun's 11" Induction Flood Type Wall Pack fixtures feature classic form and durability to make it an excellent choice for new construction or retrofit applications. Neptun's Induction Wall Pack fixtures feature a high CRI and bright white 5000°K color temperature for increased safety and security. It can replace existing HID fixtures up to 100W.

APPLICATION

- Building Accent Lighting
- Landscape Lighting
- Security Lighting
- Parking Lot Lighting
- Area Lighting
- Storage Area Lighting

STRUCTURE, MATERIALS, & FEATURES

- Heavy-gauge, die-cast aluminum housing.
- Custom designed anodized aluminum reflectors for superior illuminance.
- Heat and impact resistant rounded borosilicate glass lens.
- Corrosion resistant electrocoat dark bronze finish (custom colors available).
- Hinged aluminum door frame incorporates stainless steel hardware.
- Continuous silicone gasketing surrounds lens for weather - tight seal.
- Inductively coupled rectangular induction bulb.
- High power factor, low THD electronic ballast with surge protection.
- Instant-On flicker-free Cold Start and Hot Re-Start.
- High quality glare-free light with high CRI above (83).
- Bright white light (5000°K) for greater visibility and safety.
- Advance phosphors for high lumen output and high lumen maintenance.
- Up to 20 year maintenance free operation.
- 10 Year Warranty.
- **Optional:** DC 24V Operation - Solar Compatible

ORDERING INFORMATION

Sample Number: 21040-RFLD-UNV-850-LD-120V-BRZ
Custom options and accessories available. Please consult factory

Series	Wattage	Lens Type	Voltage	Color Temp	Accessories	Color
21 = Wall Pack	040 = 40 W	RFLD = Flood Type Rounded Lens	UNV = 120-277 VAC 24VDC = 24V DC	830 = 3000°K 841 = 4100°K 850 = 5000°K* * Standard	LD-120V = Photocell for 120V LD-277V = Photocell for 277V MD = Motion Sensor	BRZ = Dark Bronze * Custom Colors Available



lightinnovations@work™

PRODUCT INFORMATION

Model No.	Description	Rated Watts	Input Watts	Initial Lumens	Universal Line Voltage (VAC)	Max Line Current (Amp) @ 120 - 277	THD	Power Factor	Weight
21040-RL-SCT-UNV	Wall Pack - Semi Cut-Off	40	42	3,200	120-277	0.35-0.15	<10%	0.98	15 lbs

SPECIFICATIONS

- Ballast Type Electronic
- Start Method InstantON
- Hot Re-start InstantON
- Universal Input Line Voltage 120-277 VAC
- Input Line Frequency 50/60 Hz
- Lamp Operating Frequency 250 kHz
- Ballast Off-State Draw 0 Watts
- Sound Rating Class A
- ANSI Surge Protection Class A
- Lamp / Ballast System Life 100,000 Hrs.
- Lumen Maintenance @75,000Hrs > 70%
- Color Temperature 5000°K
- Color Rendering Index (CRI) 83
- Minimum Starting Temperature -20°F
- Maximum Starting Temperature 160°F
- Lumens per Watt 80
- Shock / Vibration Resistant Yes
- Power Factor > 0.98
- Total Harmonic Distortion < 10%
- Inrush Current Peak < 10 Amp
- ETL Listed / UL Standard 1598 Yes
- FCC Compliance Part 18, Subp. C
- IP Rating IP65
- Warranty 10 Year

MOUNTING OPTIONS

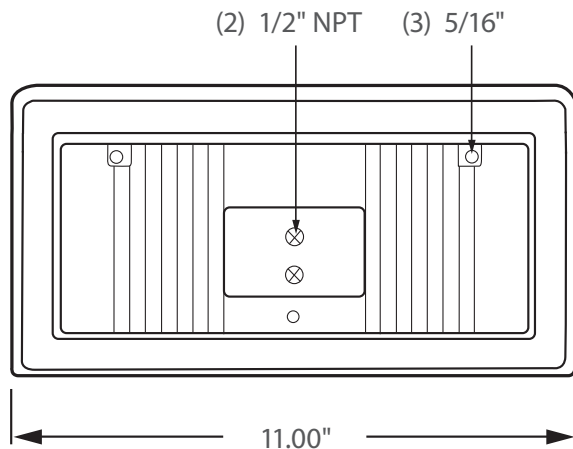

PHOTOMETRICS (See Complete IES File)

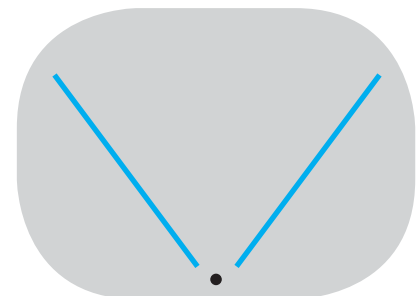

Type IV Distribution

Neptun Light, Inc.
 13950 Business Center Drive
 Lake Forest, IL 60045
 Fax: 847.735.8004

Neptun Light, Inc. reserves the right to change materials or modify the design of its product without notification as part of the company's continuing product improvement program.
 ©2002-2016 Neptun Light, Inc. All rights reserved. Spec. Rev. 4-2016