

Incredible **100,000 hrs**

### GENERAL DESCRIPTION

Neptun's 18" Induction Flood Type Wall Pack fixtures feature classic form and durability to make it an excellent choice for new construction or retrofit applications. Neptun's Induction Wall Pack fixtures feature a high CRI and bright white 5000°K color temperature for increased safety and security. It can replace existing HID fixtures up to 400W.

### APPLICATION

- Building Accent Lighting
- Landscape Lighting
- Security Lighting
- Parking Lot Lighting
- Area Lighting
- Storage Area Lighting

### STRUCTURE, MATERIALS, & FEATURES

- Heavy-gauge, die-cast aluminum housing.
- Custom designed anodized aluminum reflectors for superior illuminance.
- Heat and impact resistant rounded borosilicate glass lens.
- Corrosion resistant electrocoat dark bronze finish (custom colors available).
- Hinged aluminum door frame incorporates stainless steel hardware.
- Continuous silicone gasketing surrounds lens for weather - tight seal.
- Inductively coupled rectangular induction bulb.
- High power factor, low THD electronic ballast with surge protection.
- Instant-On flicker-free Cold Start and Hot Re-Start.
- High quality glare-free light with high CRI above (83).
- Bright white light (5000°K) for greater visibility and safety.
- Advance phosphors for high lumen output and high lumen maintenance.
- Up to 20 year maintenance free operation.
- 10 Year Warranty.
- **Optional:** DC 24V Operation - Solar Compatible

### ORDERING INFORMATION

Sample Number: 21080-RFLD-UNV-850-LD-120V-BRZ  
 Custom options and accessories available. Please consult factory

Series	Wattage	Lens Type	Voltage	Color Temp	Accessories	Color
21 = Wall Pack	080 = 80 W 100 = 100 W 120 = 120 W 150 = 150 W 200 = 200 W	RFLD = Flood Type Rounded Lens	UNV = 120-277 VAC 24VDC = 24V DC * * Only Available up to 100W	830 = 3000°K 841 = 4100°K 850 = 5000°K * * Standard	LD-120V = Photocell - 120V LD-277V = Photocell - 277V MD = Motion Sensor	BRZ = Dark Bronze * Custom Colors Available



lightinnovations@work™

### PRODUCT INFORMATION

Model No.	Description	Rated Watts	Input Watts	Initial Lumens	Universal Line Voltage (VAC)	Max Line Current (Amp) @ 120 - 277	THD	Power Factor	Weight
21080-RL-SCT-UNV	Wall Pack - Semi Cut-Off	80	82	6,400	120-277	0.69-0.30	<10%	0.98	20 lbs
21100-RL-SCT-UNV	Wall Pack - Semi Cut-Off	100	105	8,000	120-277	0.87-0.37	<10%	0.98	20 lbs
21120-RL-SCT-UNV	Wall Pack - Semi Cut-Off	120	125	9,600	120-277	1.05-0.45	<10%	0.98	20 lbs
21150-RL-SCT-UNV	Wall Pack - Semi Cut-Off	150	158	12,000	120-277	1.31-0.56	<10%	0.98	23 lbs
21200-RL-SCT-UNV	Wall Pack - Semi Cut-Off	200	210	16,000	120-277	1.74-0.75	<10%	0.98	23 lbs

### SPECIFICATIONS

- Ballast Type ..... Electronic
- Start Method ..... InstantON
- Hot Re-start ..... InstantON
- Universal Input Line Voltage ..... 120-277 VAC
- Input Line Frequency ..... 50/60 Hz
- Lamp Operating Frequency ..... 250 kHz
- Ballast Off-State Draw ..... 0 Watts
- Sound Rating ..... Class A
- ANSI Surge Protection ..... Class A
- Lamp / Ballast System Life ..... 100,000 Hrs.
- Lumen Maintenance @75,000Hrs ..... > 70%
- Color Temperature ..... 5000°K
- Color Rendering Index (CRI) ..... 83
- Minimum Starting Temperature ..... -20°F
- Maximum Starting Temperature ..... 160°F
- Lumens per Watt ..... 80
- Shock / Vibration Resistant ..... Yes
- Power Factor ..... > 0.98
- Total Harmonic Distortion ..... < 10%
- Inrush Current Peak ..... < 10 Amp
- ETL Listed / UL Standard 1598 ..... Yes
- FCC Compliance ..... Part 18, Subp. C
- IP Rating ..... IP65
- Warranty ..... 10 Year

### MOUNTING OPTIONS

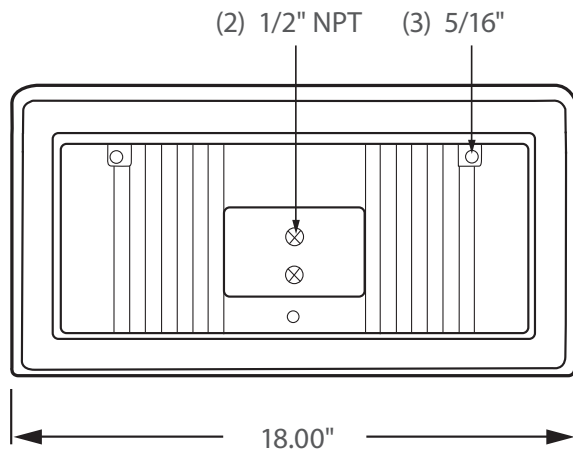

### PHOTOMETRICS (See Complete IES File)

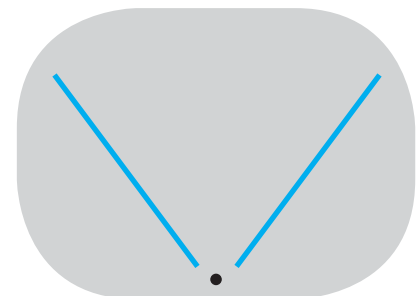

Type IV Distribution

Neptun Light, Inc.  
 13950 Business Center Drive  
 Lake Forest, IL 60045  
 Fax: 847.735.8004

Neptun Light, Inc. reserves the right to change materials or modify the design of its product without notification as part of the company's continuing product improvement program.  
 ©2002-2016 Neptun Light, Inc. All rights reserved. Spec. Rev. 4-2016