

Incredible **100,000 hrs**

GENERAL DESCRIPTION

Neptun's Low Profile Induction Flood Type Wall Pack fixtures feature architectural design and durability to make it an excellent choice for new construction or retrofit applications. Neptun's Induction Wall Pack fixtures feature a high CRI and bright white 5000°K color temperature for increased safety and security. They can replace existing HID & HPS fixtures up to 100 Watts.

APPLICATION

- Building Accent Lighting
- Landscape Lighting
- Doorway Lighting
- Security Lighting
- Area Lighting

STRUCTURE, MATERIALS, & FEATURES

- Heavy-gauge, die-cast aluminum housing.
- Custom designed anodized aluminum reflectors for superior illuminance.
- Heat and impact resistant, UV protected, non yellowing polycarbonate refractor / lens.
- Corrosion resistant electrocoat black finish (custom colors available).
- Hinged aluminum door frame incorporates stainless steel hardware.
- Continuous silicone gasketing surrounds lens for weather - tight seal.
- Inductively coupled rectangular induction bulb.
- High power factor, low THD electronic ballast with surge protection.
- Instant-On flicker-free Cold Start and Hot Re-Start.
- High quality glare-free light with high CRI above (83).
- Bright white light (5000°K) for greater visibility and safety.
- Advance phosphors for high lumen output and high lumen maintenance.
- Up to 20 year maintenance free operation.
- 10 Year Warranty.
- **Optional:** DC 24V Operation - Solar Compatible

ORDERING INFORMATION

Sample Number: 43040FLD-UNV-850-LD-120V-BLK
 Custom options and accessories available. Please consult factory

Series	Wattage	Lens Type	Voltage	Color Temp	Accessories	Color
43 = Wall Pack	040 = 40 W	FLD = Flood Type	UNV = 120-277 VAC 24VDC = 24V DC	830 = 3000°K 841 = 4100°K 850 = 5000°K* * Standard	LD-120V = Photocell for 120V LD-277V = Photocell for 277V MD = Motion Sensor	BLK = Black * Custom Colors Available



lightinnovations@work™

PRODUCT INFORMATION

Model No.	Description	Rated Watts	Input Watts	Initial Lumens	Universal Line Voltage (VAC)	Max Line Current (Amp) 120 - 277	THD	Power Factor	Weight
43040FLD-UNV	Wall Pack - Flood Fixture	40	41	3,200	120-277	0.35-0.15	<10%	0.98	15 lbs

SPECIFICATIONS

- Ballast Type Electronic
- Start Method InstantON
- Hot Re-start InstantON
- Universal Input Line Voltage 120-277 VAC
- Input Line Frequency 50/60 Hz
- Lamp Operating Frequency 250 kHz
- Ballast Off-State Draw 0 Watts
- Sound Rating Class A
- ANSI Surge Protection Class A
- Lamp / Ballast System Life 100,000 Hrs.
- Lumen Maintenance @75,000Hrs > 70%
- Color Temperature 5000°K
- Color Rendering Index (CRI) 83
- Minimum Starting Temperature -20°F
- Maximum Starting Temperature 160°F
- Lumens per Watt 80
- Shock / Vibration Resistant Yes
- Power Factor > 0.98
- Total Harmonic Distortion < 10%
- Inrush Current Peak < 10 Amp
- ETL Listed / UL Standard 1598 Yes
- FCC Compliance Part 18, Subp. C
- IP Rating IP65
- Warranty 10 Year

MOUNTING OPTIONS

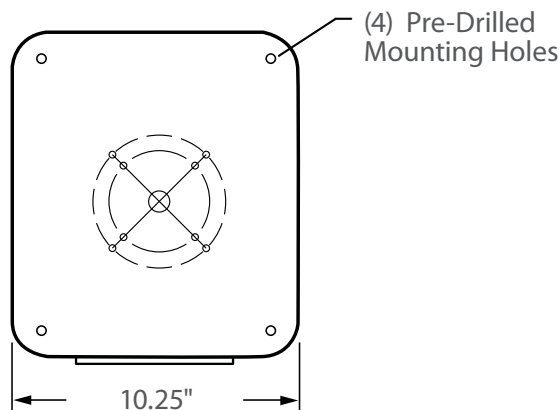

PHOTOMETRICS (See Complete IES File)

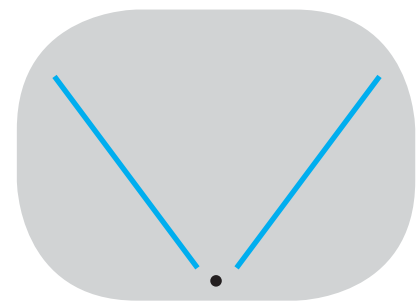

Type IV Distribution

Neptun Light, Inc.
 13950 Business Center Drive
 Lake Forest, IL 60045
 Fax: 847.735.8004

Neptun Light, Inc. reserves the right to change materials or modify the design of its product without notification as part of the company's continuing product improvement program.
 ©2002-2016 Neptun Light, Inc. All rights reserved. Spec. Rev. 4-2016